

USB Extender Plus T/R

Twisted Pair Extenders for USB Peripherals



Safety Instructions

Safety Instructions • English

WARNING: This symbol, ⚠, when used on the product, is intended to alert the user of the presence of uninsulated dangerous voltage within the product's enclosure that may present a risk of electric shock.

ATTENTION: This symbol, ⚠, when used on the product, is intended to alert the user of important operating and maintenance (servicing) instructions in the literature provided with the equipment.

For information on safety guidelines, regulatory compliances, EMI/EMF compatibility, accessibility, and related topics, see the Extron Safety and Regulatory Compliance Guide, part number 68-290-01, on the Extron website, www.extron.com.

Instructions de sécurité • Français

AVERTISSEMENT : Ce pictogramme, ⚠, lorsqu'il est utilisé sur le produit, signale à l'utilisateur la présence à l'intérieur du boîtier du produit d'une tension électrique dangereuse susceptible de provoquer un choc électrique.

ATTENTION : Ce pictogramme, ⚠, lorsqu'il est utilisé sur le produit, signale à l'utilisateur des instructions d'utilisation ou de maintenance importantes qui se trouvent dans la documentation fournie avec le matériel.

Pour en savoir plus sur les règles de sécurité, la conformité à la réglementation, la compatibilité EMI/EMF, l'accessibilité, et autres sujets connexes, lisez les informations de sécurité et de conformité Extron, réf. 68-290-01, sur le site Extron, www.extron.com.

Sicherheitsanweisungen • Deutsch

WARNUNG: Dieses Symbol ⚠ auf dem Produkt soll den Benutzer darauf aufmerksam machen, dass im Inneren des Gehäuses dieses Produktes gefährliche Spannungen herrschen, die nicht isoliert sind und die einen elektrischen Schlag verursachen können.

VORSICHT: Dieses Symbol ⚠ auf dem Produkt soll dem Benutzer in der im Lieferumfang enthaltenen Dokumentation besonders wichtige Hinweise zur Bedienung und Wartung (Instandhaltung) geben.

Weitere Informationen über die Sicherheitsrichtlinien, Produkthandhabung, EMI/EMF-Kompatibilität, Zugänglichkeit und verwandte Themen finden Sie in den Extron-Richtlinien für Sicherheit und Handhabung (Artikelnummer 68-290-01) auf der Extron-Website, www.extron.com.

Instrucciones de seguridad • Español

ADVERTENCIA: Este símbolo, ⚠, cuando se utiliza en el producto, avisa al usuario de la presencia de voltaje peligroso sin aislar dentro del producto, lo que puede representar un riesgo de descarga eléctrica.

ATENCIÓN: Este símbolo, ⚠, cuando se utiliza en el producto, avisa al usuario de la presencia de importantes instrucciones de uso y mantenimiento recogidas en la documentación proporcionada con el equipo.

Para obtener información sobre directrices de seguridad, cumplimiento de normativas, compatibilidad electromagnética, accesibilidad y temas relacionados, consulte la Guía de cumplimiento de normativas y seguridad de Extron, referencia 68-290-01, en el sitio Web de Extron, www.extron.com.

Инструкция по технике безопасности • Русский

ПРЕДУПРЕЖДЕНИЕ: Данный символ, ⚠, если указан на продукте, предупреждает пользователя о наличии неизолированного опасного напряжения внутри корпуса продукта, которое может привести к поражению электрическим током.

ВНИМАНИЕ: Данный символ, ⚠, если указан на продукте, предупреждает пользователя о наличии важных инструкций по эксплуатации и обслуживанию в руководстве, прилагаемом к данному оборудованию.

Для получения информации о правилах техники безопасности, соблюдении нормативных требований, электромагнитной совместимости (ЭМП/ЭДС), возможности доступа и других вопросах см. руководство по безопасности и соблюдению нормативных требований Extron на сайте Extron: www.extron.com, номер по каталогу - 68-290-01.

Chinese Simplified (简体中文)

警告: ⚠ 产品上的这个标志意在警告用户该产品机壳内有暴露的危险电压, 有触电危险。

注意: ⚠ 产品上的这个标志意在提示用户设备随附的用户手册中有重要的操作和维护(维修)说明。

关于我们产品的安全指南、遵循的规范、EMI/EMF 的兼容性、无障碍使用的特性等相关内容, 敬请访问 Extron 网站 www.extron.com, 参见 Extron 安全规范指南, 产品编号 68-290-01。

Chinese Traditional (繁體中文)

警告: ⚠ 若產品上使用此符號, 是為了提醒使用者, 產品機殼內存在著可能會導致觸電之風險的未絕緣危險電壓。

注意: ⚠ 若產品上使用此符號, 是為了提醒使用者, 設備隨附的用戶手冊中有重要的操作和維護(維修)說明。

有關安全性指導方針、法規遵守、EMI/EMF 相容性、存取範圍和相關主題的詳細資訊, 請瀏覽 Extron 網站: www.extron.com, 然後參閱《Extron 安全性與法規遵守手冊》, 準則編號 68-290-01。

Japanese

警告: この記号 ⚠ が製品上に表示されている場合は、筐体内に絶縁されていない高電圧が流れ、感電の危険があることを示しています。

注意: この記号 ⚠ が製品上に表示されている場合は、本機の取扱説明書に記載されている重要な操作と保守(整備)の指示についてユーザーの注意を喚起するものです。

安全上のご注意、法規厳守、EMI/EMF適合性、その他の関連項目については、エクストロンのウェブサイト www.extron.com より『Extron Safety and Regulatory Compliance Guide』(P/N 68-290-01) をご覧ください。

Korean

경고: 이 기호 ⚠ 가 제품에 사용될 경우, 제품의 인클로저 내에 있는 접지되지 않은 위험한 전류로 인해 사용자가 감전될 위험이 있음을 경고합니다.

주의: 이 기호 ⚠ 가 제품에 사용될 경우, 장비와 함께 제공된 책자에 나와 있는 주요 운영 및 유지보수(정비) 지침을 경고합니다.

안전 가이드라인, 규제 준수, EMI/EMF 호환성, 접근성, 그리고 관련 항목에 대한 자세한 내용은 Extron 웹 사이트(www.extron.com)의 Extron 안전 및 규제 준수 안내서, 68-290-01 조항을 참조하십시오.

FCC Class A Notice

This equipment has been tested and found to comply with the limits for a Class A digital device, pursuant to part 15 of the FCC rules. The Class A limits provide reasonable protection against harmful interference when the equipment is operated in a commercial environment. This equipment generates, uses, and can radiate radio frequency energy and, if not installed and used in accordance with the instruction manual, may cause harmful interference to radio communications. Operation of this equipment in a residential area is likely to cause interference. This interference must be corrected at the expense of the user.

NOTES:

- This unit was tested with shielded I/O cables on the peripheral devices. Shielded cables must be used to ensure compliance with FCC emissions limits.
- For more information on safety guidelines, regulatory compliances, EMI/EMF compatibility, accessibility, and related topics, see the “[Extron Safety and Regulatory Compliance Guide](#)” on the Extron website.

Copyright

© 2014 Extron Electronics. All rights reserved.

Trademarks

All trademarks mentioned in this guide are the properties of their respective owners.

The following registered trademarks[®], registered service marks^(SM), and trademarks^(TM) are the property of RGB Systems, Inc. or Extron Electronics:

Registered Trademarks ^(®)
AVTrac, Cable Cubby, CrossPoint, eBUS, EDID Manager, EDID Minder, Extron, Flat Field, GlobalViewer, Hideaway, Inline, IP Intercom, IP Link, Key Minder, LockIt, MediaLink, PlenumVault, PoleVault, PowerCage, Pure3, Quantum, SoundField, SpeedMount, SpeedSwitch, System <i>INTEGRATOR</i> , TeamWork, TouchLink, V-Lock, VersaTools, VN-Matrix, VoiceLift, WallVault, WindoWall, XTP, and XTP Systems
Registered Service Mark^(SM) : S3 Service Support Solutions
Trademarks ^(TM)
AAP, AFL (Accu-Rate Frame Lock), ADSP (Advanced Digital Sync Processing), Auto-Image, CableCover, CDRS (Class D Ripple Suppression), DDSP (Digital Display Sync Processing), DMI (Dynamic Motion Interpolation), Driver Configurator, DSP Configurator, DSVP (Digital Sync Validation Processing), DTP, eLink, EQIP, FastBite, FlexOS, FOXBOX, Global Configurator, IP Intercom HelpDesk, LinkLicense, MAAP, MicroDigital, ProDSP, QS-FPC (QuickSwitch Front Panel Controller), Scope-Trigger, SIS (Simple Instruction Set), Skew-Free, SpeedNav, Triple-Action Switching, WebShare, XTRA, ZipCaddy, ZipClip

Conventions Used in this Guide

Notifications

The following notifications are used in this guide:

CAUTION: Risk of minor personal injury.

ATTENTION : Risque de blessure mineure.

ATTENTION:

- Risk of property damage.
- Risque de dommages matériels.

NOTE: A note draws attention to important information.

Specifications Availability

Product specifications are available on the Extron website, www.extron.com.

Contents

Introduction	1
About this Guide.....	1
About the USB Extender Plus T/R	1
Features	1
Application Diagram	2

Installation and Operation	3
Connection Guidelines.....	3
Rear Panel Connections	3
Transmitter Rear Panel.....	3
Receiver Rear Panel	5
Cabling and Setup.....	5
Installation Overview	6
Pairing the Transmitter and Receiver	7
Connecting for Serial Communication.....	8
Enabling and Disabling Peripheral Emulation.....	8
Front Panel Features.....	9
Transmitter Front Panel	9
Receiver Front Panel.....	10
System Operation.....	10
Troubleshooting	11

Remote Configuration and Control.....	12
SIS Commands	12
Host-to-Extender Communications	12
Extender-initiated Message.....	12
Error Responses.....	13
Using the Command and Response Table.....	13
Symbol Definitions.....	13
Command and Response Table for SIS Commands	14

Reference Information	15
TP Cable Termination.....	15
Mounting the USB Extender Plus T/R.....	16
Tabletop Placement	16
Rack Mounting	16
Furniture Mounting.....	16

Introduction

This section provides an overview of the guide and the product. The following topics are discussed:

- [About this Guide](#)
- [About the USB Extender Plus T/R](#)
- [Features](#)

About this Guide

This user guide contains information to install, configure, and operate the Extron USB Extender Plus T/R transmitter and receiver pair. Additional product information can be found on the Extron Electronics website at www.extron.com.

In this guide the term “extender” refers to either the transmitter or the receiver. Where differences exist between the transmitter and receiver, they are noted.

About the USB Extender Plus T/R

The USB Extender Plus T/R extends signals over a single CATx twisted pair cable from USB peripheral devices that are located long distances from the host computer. It is compatible with USB 3.0, 2.0, 1.1, and 1.0 devices with high data transfer rates.

The transmitter connects directly to a USB port on a PC or USB host and includes USB peripheral emulation to enable trouble-free booting of a host computer that is not connected to a keyboard or mouse. The receiver features a built-in active four-port hub that supplies power to multiple attached USB devices.

NOTE: The transmitter and receiver pair work with unshielded twisted pair (UTP) or shielded twisted pair (STP) cables. However, to ensure FCC Class A and CE compliance, STP cables are required.

Features

- **Single CATx cable transmission** — Transmits USB signals over one CAT 5/5e/6/7 twisted pair cable.
- **Long distance transmission** — Transmits signals up to 330 feet (100 meters).
- **Provides data transfer rates up to 480 Mbps** — Allows high speed transfer from thumb drives and other mass storage devices.
- **Compatible with USB 3.0 and earlier devices.**
- **Integrated four-port hub** — The receiver has a four-port integrated USB hub, which provides 5 volts, 500 mA on each port. Simultaneous connection is provided to multiple peripheral devices such as mass storage devices, keyboards, mice, or other human interface devices (HID).
- **Peripheral emulation** — Emulates a keyboard and mouse to the host computer for a problem-free boot-up.

- **Asynchronous transfers** — Supports USB devices that require asynchronous transfers.
- **Real-time status LED indicators for troubleshooting and monitoring** — Front and rear panel LED indicators provide visual confirmation of port activity between an active host and each connected peripheral device.
- **Rack and furniture mountable** — Low-profile, 1-inch (2.5 cm) high, quarter rack wide metal enclosures enable the extenders to be installed discreetly, such as beneath a table or inside a lectern.
- **Included power supplies** — An energy-efficient, external, universal power supply, part number **70-775-01 (28-071-57LF)**, is provided with each unit. The power supply provides worldwide power compatibility with high demonstrated reliability and low power consumption.
- **Remote configuration and control** — The transmitter and receiver can be configured via Extron SIS (Simple Instruction Set) commands issued from the computer to the front panel 2.5 mm TRS Config port of the extenders.

Application Diagram

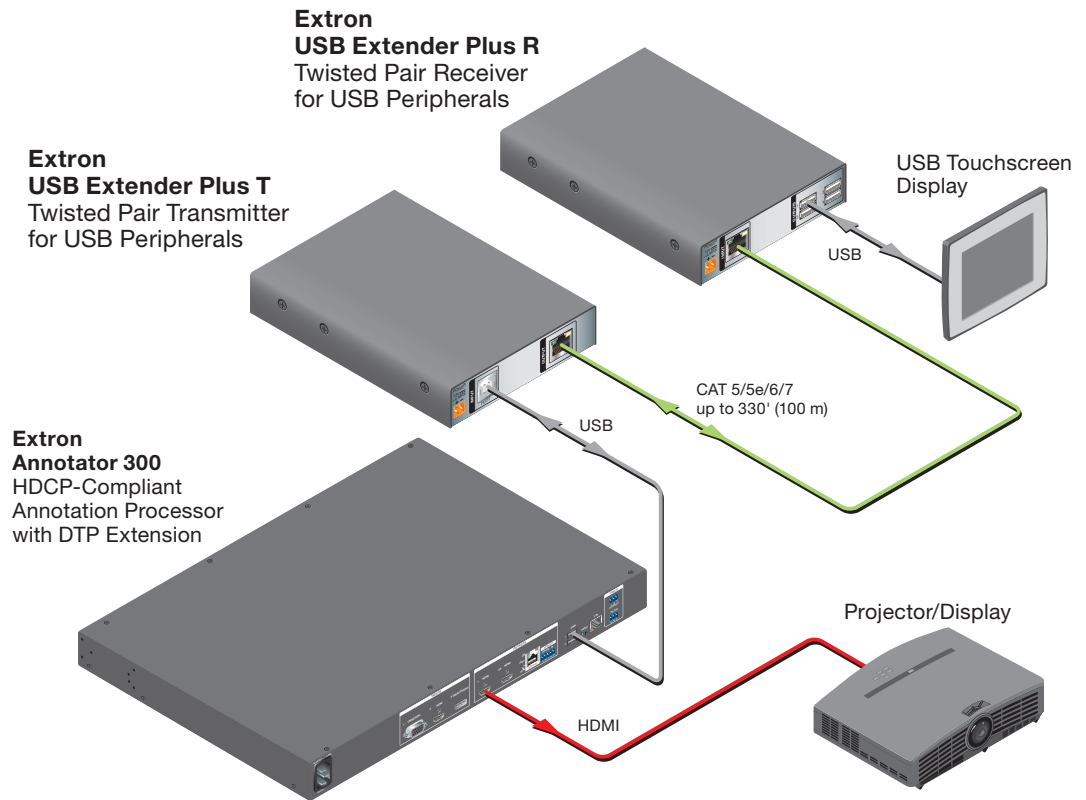

Figure 1. USB Extender Plus T/R Application with the Annotator 300

Installation and Operation

This section provides the following details:

- [Connection Guidelines](#)
- [Rear Panel Connections](#)
- [Cabling and Setup](#)
- [Front Panel Features](#)
- [System Operation](#)
- [Troubleshooting](#)

Connection Guidelines

The USB Extender Plus T/R can be installed in existing and new systems within the following guidelines:

- USB extenders cannot be cascaded (you cannot sequentially connect a USB Extender Plus T/R to another USB Extender Plus T/R or to a FOX T/R USB Extender Plus).
- The maximum number of USB hubs that can be connected downstream is four, when peripheral emulation is disabled, and three when it is enabled.
- The USB Extender Plus T/R is able to support a maximum of 31 downstream USB devices (including hubs). For example, if two 4-port USB hubs are connected to a receiver, that totals ten devices (two hub connections plus the eight hub ports).

Rear Panel Connections

Transmitter Rear Panel



- A** Power connector
- B** Host (Input) connector
- C** Output connector

Figure 2. Transmitter Rear Panel Connectors

- A Power connector** — Connect a provided 12 VDC, 1 A max. external power supply to this 2-pole, 3.5 mm captive screw connector.

ATTENTION:

- The power supply must not be permanently fixed to the building structure or similar structures.
- La source d'alimentation ne devra pas être fixée de façon permanente à une structure de bâtiment ou à une structure similaire.
- Do not place the power supply within environmental air handling spaces or the wall cavity.
- Ne pas placer les sources d'alimentation dans une zone de traitement de l'air ni dans une cavité murale.
- The installation must be in accordance with the applicable provisions of the *National Electrical Code ANSI/NFPA 70, Article 725* and the *Canadian Electrical Code, Part 1, Section 16*.
- Cette installation doit toujours être en accord avec les mesures qui s'applique au National Electrical Code ANSI/NFPA 70, article 725, et au Canadian Electrical Code, partie 1, section 16.
- The power supply must be located within the same vicinity as the Extron AV processing equipment in an ordinary location, Pollution Degree 2, secured to a podium, a desk, or an equipment rack within a dedicated closet.
- La source d'alimentation doit être située à proximité de l'équipement audiovisuel Extron dans un emplacement habituel, avec un degré de pollution 2, fixée à une estrade, un bureau, ou dans une baie technique à l'intérieur d'un placard dédié.
- Always use a power supply specified by Extron for the MLC. Use of an unauthorized power supply voids all regulatory compliance certification and may cause damage to the supply and the MLC.
- Utilisez toujours une source d'alimentation fournie ou recommandée par Extron. L'utilisation d'une source d'alimentation non autorisée annule toute conformité réglementaire et peut endommager la source d'alimentation ainsi que le produit final.

- B Host (input) connector** — Connect a USB A-B cable between this port and the USB port of a host computer. The USB Extender Plus is USB 3.0 compliant and supports data transfers of 480 Mbps (high speed), 12 Mbps (full speed), and 1.5 Mbps (low speed).
- C Output (twisted pair) connector** — Connect a TP cable from the RJ-45 Input connector of the receiver (see [figure 3](#), **B**, on the next page) to this female RJ-45 connector.

Receiver Rear Panel



Figure 3. Receiver Rear Panel Connectors

- A Power input connector** — Connect a provided 12 VDC power supply into this 2-pole, 3.5 mm captive screw connector.

Important: Do not connect power to this port until you have read the **Attention** notices on the previous page.

- B Input (twisted pair) connector** — Connect the TP cable from the RJ-45 Output connector of the transmitter (see [figure 2, C](#), on page 3) to this female RJ-45 connector.

- C USB hub connectors** — The built-in four port hub has four female USB Type A connectors. The connections are USB 3.0 compatible, providing +5 VDC at up to 500 mA to connected USB peripherals requiring power.

See [TP Cable Termination](#) on page 15 to wire the RJ-45 connectors if necessary.

Cabling and Setup

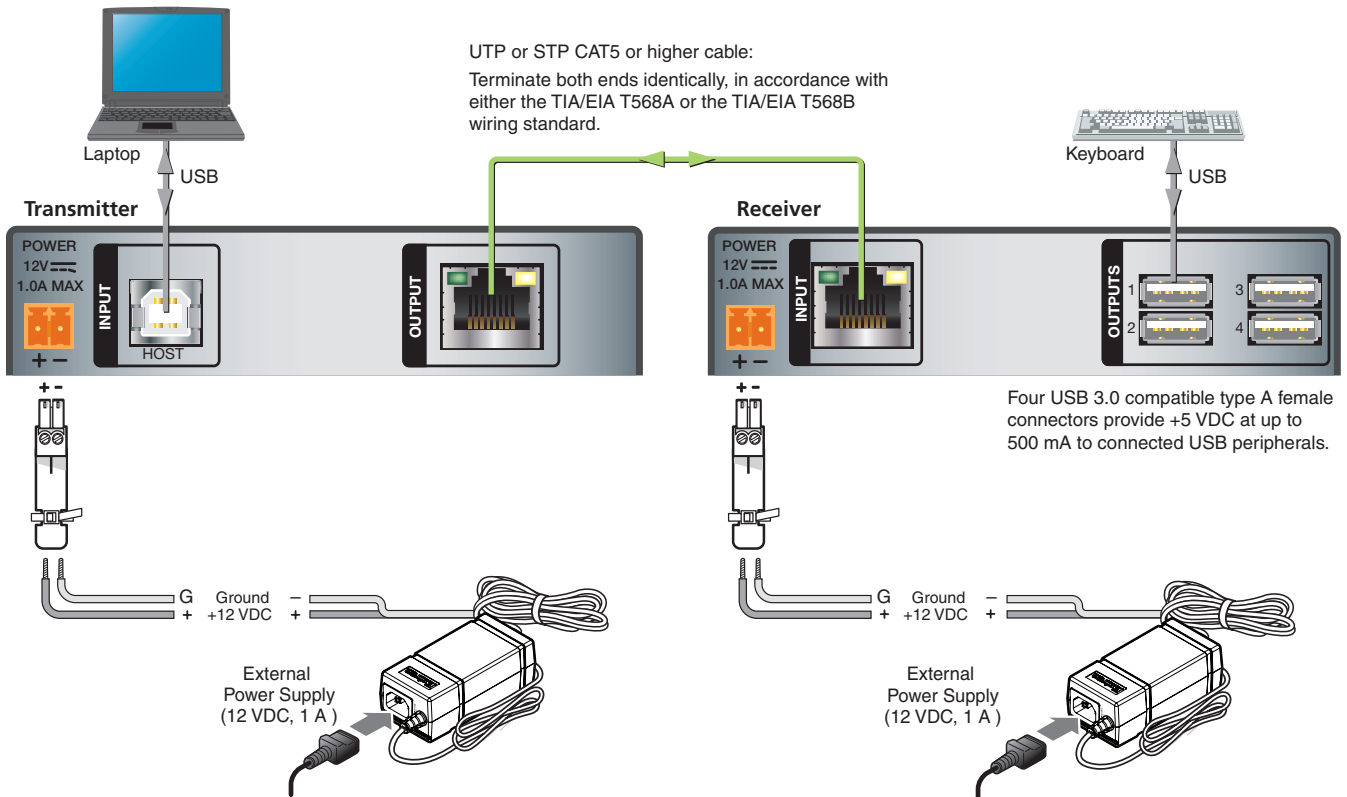



Figure 4. USB Extender Plus T-R Connection with Two External Power Supplies

Installation Overview

ATTENTION:

- Installation and service must be performed by authorized personnel only.
- L'installation et l'entretien doivent être effectués par le personnel autorisé uniquement.

To ensure proper operation, the transmitter, receiver, USB host, and USB peripherals must be connected properly and in the sequence described below (see [figure 4](#) on the previous page).

1. Power off the USB host computer connected to the transmitter and all devices that will be directly connected to the receiver.
2. If desired, choose a location and mount the transmitter and receiver (see the instructions for the selected mounting option for the mounting procedure).
 - If rack mounting, fasten the enclosure to the rack or rack shelf.
 - If furniture mounting, install the mounting brackets (not included), then fasten the brackets to the furniture.
 - For table mounting, attached the provided four rubber feet to the bottom of the unit and place it where desired.
3. Connect a CATx twisted pair cable to the RJ-45 Output port of the transmitter and the Input port of the receiver.
4. Connect the external power supplies (provided) to the transmitter and to the receiver. The green power LEDs (shown at right) on the front panels of both extenders light. 
5. Power on the host computer if you have not done so.
6. Pair the transmitter with the receiver (see [Pairing the Transmitter and Receiver](#) on the next page). When the pairing process is complete, the Link LEDs on the front panels of the transmitter and receiver light.
7. Connect a USB Type A-B cable from a USB port of the host computer to the transmitter Host port. Shortly after, the Host LED on the receiver starts blinking, indicating that communication between the USB and host has been established.
8. Connect up to four USB peripheral devices (such as a keyboard, mouse, scanner, or printer) to the receiver Hub ports. When the first device is connected, the Host LED stops blinking and remains lit steadily. As each peripheral device is connected, the LED for its hub port lights when the host PC detects the device.
9. If desired, connect a 9-pin D-to-2.5 mm TRS cable between a computer and the front panel Config port on the transmitter, receiver, or both to configure the units via SIS commands (see [Connecting for Serial Communication](#) on page 8).

The system is now ready to operate.

Pairing the Transmitter and Receiver

In order to function together, the transmitter and receiver must be paired the first time they are used together. Both units must be connected together through their RJ-45 connectors (the transmitter Output connector and the receiver Input connector) and powered on.

NOTES:

- After they have been paired, the transmitter and receiver can be powered down and disconnected from each other.
- A transmitter and receiver need to be paired only once (at startup). If the paired units are reconnected and powered on, they do not have to be paired again.

You can initiate pairing from either the transmitter or the receiver (the procedure described below is for transmitter-to-receiver pairing).

1. Using a stylus or small screwdriver, press the recessed **Pair** button (see [figure 6](#), **B**, on the page 9) on the transmitter front panel and hold it for 1 second. The front panel Link LED on the transmitter (see [figure 6](#), **F**) begins blinking as pairing is initiated.
2. Within 10 minutes of pressing the transmitter **Pair** button, press the receiver **Pair** button and hold it for 1 second. The Link LED on the receiver front panel (**F**) begins blinking.

When the LEDs of both units have stopped blinking and remain lit steadily, the pairing is complete.

Canceling pairing

To stop the pairing process before it completes, do either of the following:

- Do not perform step 2 of the pairing process described above (that is, do not press the **Pair** button within 10 minutes).
- Press the transmitter **Pair** button and hold it for 1 second. The Link LED turns off.

Unpairing the transmitter and receiver

To unpair a transmitter and receiver that have been paired together:

1. Press and hold the **Pair** button on either the transmitter or receiver until the transmitter Link LED turns off and the Link LED on the receiver begins to blink (approximately 10 seconds).
2. Release the **Pair** button.

Connecting for Serial Communication

The front panel Config ports on both the transmitter and the receiver (see [figure 6](#), **C**, on the next page and [figure 7](#), **C**, on page 10) enable communication with a computer via an RS-232 connection. Connect a 9-pin D-to-2.5 mm cable from the computer serial port to the Config port on the transmitter or receiver front panel to enable serial communication. SIS commands can be entered at the computer and issued to the transmitter or receiver through these ports to control and configure the unit. The protocol for the ports is 9600 baud, 8 data bits, 1 stop bit, and no parity.

An optional 9-pin D-to-2.5 mm TRS configuration cable is available from Extron and can be used to connect your computer to this port. Figure 5 shows the configuration and pin assignments of this cable.

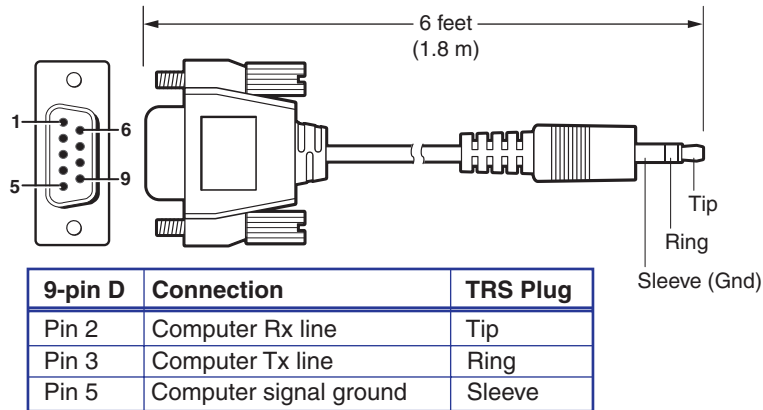

Figure 5. Optional 9-pin D to 2.5 mm TRS Cable for the Config Port

Enabling and Disabling Peripheral Emulation

The transmitter can be set up to emulate a mouse and keyboard to the host computer that is connected to the transmitter Host input port. This allows the computer to boot up in the event that it requires a USB keyboard or mouse to be present.

When peripheral emulation is **disabled**, up to **four** USB hubs can be connected in a series to the receiver. When peripheral emulation is **enabled**, up to **three** hubs can be connected.

Using SIS commands, you can disable and enable peripheral emulation. By default, peripheral emulation is enabled.

The following peripheral emulation commands can be issued to the **transmitter only**:

- **To disable:** `[Esc] E 0 USBC←`
- **To enable:** `[Esc] E 1 USBC←`

See [Remote Configuration and Control](#), beginning on page 12, for information on entering SIS commands.

Front Panel Features

Transmitter Front Panel

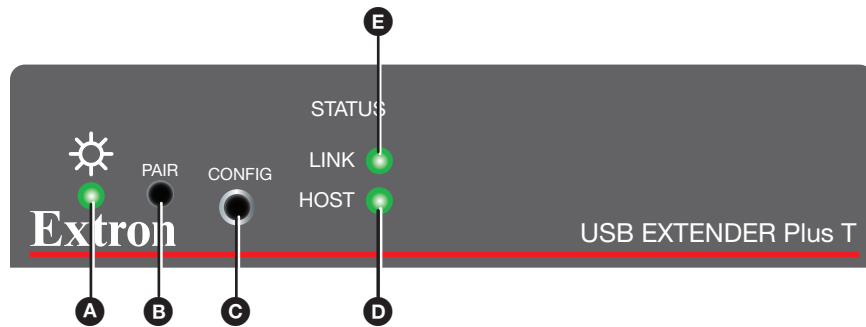

Figure 6. Transmitter Front Panel

- A Power LED** — This green LED lights to indicate that the unit is receiving power.
- B Pair button** — This recessed button pairs the transmitter with the receiver, which must be done before operation the first time they are used together. Use a small screwdriver or stylus to press it (see [Pairing the Transmitter and Receiver](#) on page 7).
- C Config port** — Connect a 9-pin D-to-2.5 mm TRS cable from a computer to this 2.5 mm TRS jack for RS-232 communication (see [Connecting for Serial Communication](#) on the previous page). The Config port enables serial communication with the computer for configuration and control of the transmitter via SIS commands (see [Remote Configuration and Control](#)).
- D Host LED** — This green LED lights when the transmitter is powered and is communicating with the host PC.
- E Link LED** — This green LED lights when the transmitter and receiver are successfully paired, connected together by the twisted pair cabling, and receiving power.

While the transmitter is being paired with the receiver, this LED blinks. When the pairing process is completed, the LED lights steadily.

Receiver Front Panel

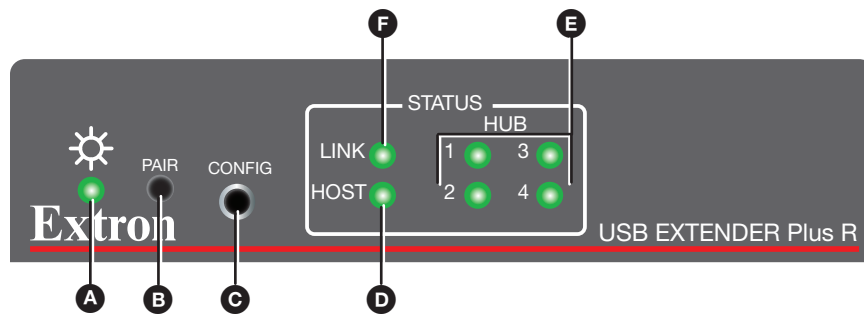

Figure 7. Receiver Front Panel

- A Power LED** — This green LED lights to indicate that the unit is receiving power.
- B Pair button** — This recessed button pairs the receiver with the transmitter, which must be done before operation the first time they are used together. Use a small screwdriver or stylus to press it (see [Pairing the Transmitter and Receiver](#) on page 7).
- C Config port** — Connect a 9-pin D-to-2.5 mm TRS cable from a computer to this 2.5 mm TRS jack for RS-232 communication (see [Connecting for Serial Communication](#) on page 8). The Config port enables serial communication with the computer for configuration and control of the receiver via SIS commands (see [Remote Configuration and Control](#), beginning on page 12).
- D Host LED** — This green LED blinks when both the transmitter and receiver are powered, both are correctly connected by the twisted pair cable, and the receiver is communicating with the host PC.

Blinks when the transmitter and receiver are both powered and connected, but no USB devices are connected.
- E Hub LEDs** — A single green LED for each port lights when the peripheral device connected to the associated USB port is recognized by the host PC.
- F Link LED** — This green LED lights when the transmitter and receiver are successfully paired, connected together by the twisted pair cabling, and receiving power.

While the receiver is being paired with the transmitter, this LED blinks. When the pairing process is completed, the LED lights steadily.

System Operation

No drivers are required for a host PC to function with the USB Extender Plus T/R. The transmitter is detected by the operating system and appropriate USB drivers are loaded. Certain USB peripherals, such as gaming keyboards, USB interactive whiteboards, scanners, printers, and similar devices, require specific drivers installed on the PC. See the USB device installation instructions or the website of the peripheral device manufacturer to obtain drivers.

Once the transmitter, the receiver, the PC or USB host, and peripherals are connected, have appropriate drivers loaded, and are powered up, the system is fully operational. If problems are encountered, ensure all cables are routed and connected properly and the latest drivers for each peripheral are installed.

Troubleshooting

USB signals are generally reliable but are susceptible to bad connections or cables that are too long. The TP cable can have the same issues. To avoid the loss of data and communications, follow these guidelines:

- The USB cables that connect the transmitter to the host or the receiver hub ports to peripheral devices should not exceed 6 feet (1.8 meters).
- When connecting the host or peripherals, use only cable designed for USB signals.
- Avoid or limit the use of adapters.
- The USB Extender Plus works as described in point-to-point applications. Do not use additional adapters, patch panels, or couplers with the host USB cables, hub USB cables, or twisted pair cables. Additional links in the signal chain can result in the reduction of signal integrity and overall system performance.

When properly connected and operating, the transmitter and receiver Power LEDs, Link LEDs and Host LEDs are lit. The Hub LED for each connected peripheral recognized by the host PC is also lit.

Front panel LEDs are also useful for troubleshooting. The following table outlines operating details indicated by the LEDs.

	Transmitter		Receiver)	
LED Indicator	On	Off	On	Off
Power	12 VDC power supply is connected and operating properly.	12 VDC power supply is not connected or is defective.	12 VDC power supply is connected and operating properly.	12 VDC power supply is not connected or defective.
Link	Both transmitter and receiver are paired, have power, and are connected properly by the TP cable.	If both Power LEDs are on, the TP cable is not connected or is improperly wired, or the units are not paired. If either Power LED is off, see the Power LED troubleshooting instructions, above.	Both transmitter and receiver are paired, have power, and are connected properly by the TP cable.	If both Power LEDs are on, the TP cable is not connected or is improperly wired, or the units are not paired. If either Power LED is off, see the Power LED troubleshooting instructions, above.
Host	When transmitter power LED is on, lights when communication with host PC is established.	If transmitter power LED is on, USB cable is not connected.	Lights when communication with host PC is established. Blinks if power and Link LEDs are on, but no USB devices are connected.	Host USB port is not connected or host is not communicating.
Hub	N/A	N/A	Lights when a connected peripheral is recognized by the host PC.	A peripheral device connected to the USB port has not been recognized or is improperly connected.

Table 1: System Troubleshooting

Remote Configuration and Control

This section describes the connection through which the USB Extender Plus can be configured and controlled remotely via Simple Instruction Set (SIS) commands, and describes the commands that are available. Topics include:

- [SIS Commands](#)
- [Host-to-Extender Communications](#)
- [Using the Command and Response Table](#)
- [Command and Response Table for SIS Commands](#)

SIS Commands

The USB Extender Plus can be remotely set up and controlled via a host computer or other device (such as a control system) that is attached to the front panel Config port (see [Connecting for Serial Communication](#) on page 8 for information on connecting to this port). You can issue SIS commands to the extender using your computer RS-232 interface with a communication software program such as Extron DataViewer or HyperTerminal.

NOTE: The SIS command for resetting must be issued to both the transmitter and the receiver. Do not reset one unit without resetting the other.

Host-to-Extender Communications

SIS commands consist of one or more characters per field. No special characters are required to begin or end a command sequence. When the USB Extender Plus determines that a command that was entered is valid, it executes the command and sends a response to the host device.

Most responses from the USB Extender Plus T/R to the host computer end with a carriage return and a line feed (CR/LF = `]`), which signals the end of the response character string. A string is one or more characters.

Extender-initiated Message

When power is applied to the extender, it sends the following copyright message:

© Copyright 20nn, Extron Electronics USB Extender Plus, Vn.nn

where Vn.nn is the firmware version number.

NOTE: This message is displayed only when power is applied to the extender while it is connected to the computer via the Config port.

Error Responses

If the extender is unable to execute a command it receives because the command is invalid or contains invalid parameters, the USB Extender Plus T-R returns an error response to the host. Error response codes and their descriptions are:

- E10 – Invalid command
- E12 – Invalid port number
- E13 – Invalid value (out of range)
- E14 – Not valid for this configuration
- E22 – Busy
- E24 – Privilege violation
- E25 – Device not present

Using the Command and Response Table

The **Command and Response Table** on the next page lists valid ASCII command codes, the responses of the extender to the host, and descriptions of the command functions or the results of executing the commands. The ASCII to Hex Conversion Table below is for use with the Command and Response Table.

ASCII to HEX Conversion Table										Esc 1B	CR 0D	LF 0A		
Space 20	!	21	"	22	#	23	\$	24	%	25	&	26	'	27
(28)	29	*	2A	+	2B	,	2C	-	2D	.	2E	/	2F
0 30	1	31	2	32	3	33	4	34	5	35	6	36	7	37
8 38	9	39	:	3A	;	3B	<	3C	=	3D	>	3E	?	3F
@ 40	A	41	B	42	C	43	D	44	E	45	F	46	G	47
H 48	I	49	J	4A	K	4B	L	4C	M	4D	N	4E	O	4F
P 50	Q	51	R	52	S	53	T	54	U	55	V	56	W	57
X 58	Y	59	Z	5A	[5B	\	5C]	5D	^	5E	_	5F
` 60	a	61	b	62	c	63	d	64	e	65	f	66	g	67
h 68	i	69	j	6A	k	6B	l	6C	m	6D	n	6E	o	6F
p 70	q	71	r	72	s	73	t	74	u	75	v	76	w	77
x 78	y	79	z	7A	{	7B		7C	}	7D	~	7E	DEL	7F

Symbol Definitions

- ↵ = CR/LF (carriage return and line feed) (hex 0D 0A)
- ↵ or | = Soft carriage return (no line feed)
- = Space
- [Esc] or W = Escape key (hex 1B)
- [X1] = On and off (enable and disable)
 - 0 = Off or disabled
 - 1 = On or enabled
- [X2] = Extender unit part number:
 - Transmitter: 60-1471-12
 - Receiver: 60-1471-13

NOTE: Unless otherwise indicated, commands are **not** case sensitive.

Command and Response Table for SIS Commands

Command	ASCII Command (Host to Unit)	Response (Unit to Host)	Additional Description
Information Requests			
Request part number	N	[x2] ↵	Show the extender part number [x2] . For [x2] : Transmitter: 60 - 1471 - 12 Receiver: 60 - 1471 - 13
Query firmware version	Q	<i>n.nn</i> ↵	Show the firmware version, expressed to the second decimal place.
<i>Example:</i>	Q	1.01 ↵	The unit firmware version is 1.01.
Query version and build	*Q	<i>n.nn.nnnn</i> ↵	Show firmware version and build number.
Peripheral Emulation (Transmitter Only)			
NOTE: These commands can be issued only to the transmitter.			
Set peripheral emulation	[Esc] E [x1] USBC ←	Usbc E [x1] ↵	Set peripheral emulation for the USB Extender Plus T/R to [x1] . For [x1] : 0 = disabled 1 = enabled
View peripheral emulation	[Esc] E USBC ←	[x1] ↵	
Resetting			
NOTE: This command must be issued to both the transmitter and the receiver.			
Reset	[Esc] ZXXX ←	Zpx ↵	Reset the extender to factory default values.

Reference Information

This section provides information on the following subjects:

- **TP Cable Termination**
- **Mounting the USB Extender Plus T/R**

TP Cable Termination

NOTES:

- RJ-45 termination with CAT 5, CAT 5e, CAT 6, CAT 6e, and CAT 7 cable must comply with the TIA/EIA T568A or TIA/EIA T568B wiring standard for all connections.
- The transmitter and receiver pair work with unshielded twisted pair (UTP) or shielded twisted pair (STP) cables; but to ensure FCC Class A and CE compliance, STP cables are required.
- Terminate both ends of the cable identically, in accordance with either the **TIA/EIA T 568A** or the **TIA/EIA T 568B** wiring standard.

Figure 8 shows the recommended termination of TP cables with RJ-45 connectors.

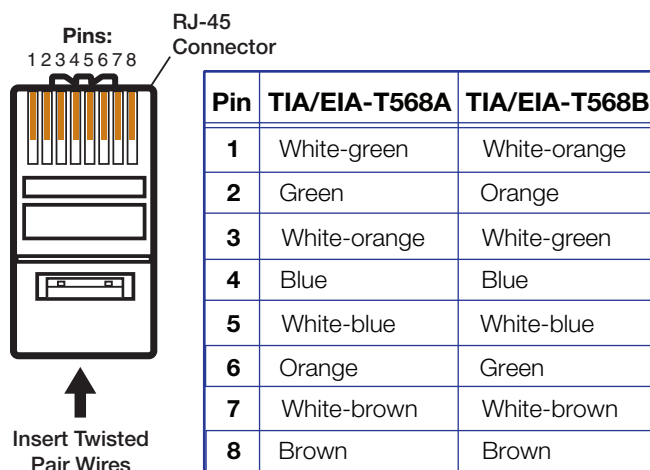

Figure 8. TP Cable Termination

NOTE: Do not use Extron UTP23SF-4 Enhanced Skew-Free™ AV UTP cable to link the transmitter and receiver. Skew-free AV cable is designed for Extron TP transmitter and receiver AV applications. The USB Extender Series does not work properly with this cable.

Mounting the USB Extender Plus T/R

The 6 inches (15 cm) deep, 1 inch (2.5 cm) high, quarter-rack wide USB Extender Plus T/R transmitter and receiver can be placed on a tabletop, mounted on a rack shelf, or mounted under a desk or tabletop. See the installation instructions in the individual mounting kits.

Tabletop Placement

Affix the four included rubber feet to the bottom of the unit and place it in any convenient location.

Rack Mounting

The following Underwriters Laboratories (UL) guidelines pertain to the safe installation of these products in a rack:

- 1. Elevated operating ambient temperature** — If the unit is installed in a closed or multi-unit rack assembly, the operating ambient temperature of the rack environment may be greater than room ambient temperature. Therefore, install the equipment in an environment compatible with the maximum ambient temperature (T_{ma}: +122 °F, +50 °C) specified by Extron.
- 2. Reduced air flow** — Install the equipment in the rack so that the equipment gets adequate air flow for safe operation.
- 3. Mechanical loading** — Mount the equipment in the rack so that uneven mechanical loading does not create a hazardous condition.
- 4. Circuit overloading** — Connect the equipment to the supply circuit and consider the effect that circuit overloading might have on overcurrent protection and supply wiring. Consider the equipment nameplate ratings when addressing this concern.
- 5. Reliable earthing (grounding)** — Maintain reliable grounding of rack-mounted equipment. Pay particular attention to supply connections other than direct connections to the branch circuit (such as the use of power strips).

To find an appropriate rack mounting kit for your installation, go to the product page at www.extron.com.

Furniture Mounting

The USB Extender Plus can be mounted to a desk, podium, or other furniture as follows:

- **Under furniture** — The unit can be mounted under a horizontal surface using an optional Under-Desk Mount Kit for eighth-rack and quarter-rack width products (see www.extron.com).
- **Through furniture** — The transmitter or receiver can be mounted through a desk or other furniture using an optional Extron Through-Desk Mounting Kit for quarter-rack or half-rack width products (see www.extron.com).

Extron Warranty

Extron Electronics warrants this product against defects in materials and workmanship for a period of three years from the date of purchase. In the event of malfunction during the warranty period attributable directly to faulty workmanship and/or materials, Extron Electronics will, at its option, repair or replace said products or components, to whatever extent it shall deem necessary to restore said product to proper operating condition, provided that it is returned within the warranty period, with proof of purchase and description of malfunction to:

**USA, Canada, South America,
and Central America:**

Extron Electronics
1230 South Lewis Street
Anaheim, CA 92805
U.S.A.

Japan:

Extron Electronics, Japan
Kyodo Building, 16 Ichibancho
Chiyoda-ku, Tokyo 102-0082
Japan

Europe and Africa:

Extron Europe
Hanzeboulevard 10
3825 PH Amersfoort
The Netherlands

China:

Extron China
686 Ronghua Road
Songjiang District
Shanghai 201611
China

Asia:

Extron Asia Pte Ltd
135 Joo Seng Road, #04-01
PM Industrial Bldg.
Singapore 368363
Singapore

Middle East:

Extron Middle East
Dubai Airport Free Zone
F12, PO Box 293666
United Arab Emirates, Dubai

This Limited Warranty does not apply if the fault has been caused by misuse, improper handling care, electrical or mechanical abuse, abnormal operating conditions, or if modifications were made to the product that were not authorized by Extron.

NOTE: If a product is defective, please call Extron and ask for an Application Engineer to receive an RA (Return Authorization) number. This will begin the repair process.

USA: 714.491.1500 or 800.633.9876
Asia: 65.6383.4400

Europe: 31.33.453.4040
Japan: 81.3.3511.7655

Units must be returned insured, with shipping charges prepaid. If not insured, you assume the risk of loss or damage during shipment. Returned units must include the serial number and a description of the problem, as well as the name of the person to contact in case there are any questions.

Extron Electronics makes no further warranties either expressed or implied with respect to the product and its quality, performance, merchantability, or fitness for any particular use. In no event will Extron Electronics be liable for direct, indirect, or consequential damages resulting from any defect in this product even if Extron Electronics has been advised of such damage.

Please note that laws vary from state to state and country to country, and that some provisions of this warranty may not apply to you.

Extron Headquarters +1.800.633.9876 (Inside USA/Canada Only) Extron USA - West +1.714.491.1500 +1.714.491.1517 FAX	Extron Europe +800.3987.6673 (Inside Europe Only) Extron USA - East +1.919.850.1000 +1.919.850.1001 FAX	Extron Asia +65.6383.4400 +65.6383.4664 FAX	Extron Japan +81.3.3511.7655 +81.3.3511.7656 FAX	Extron China +86.21.3760.1568 +86.21.3760.1566 FAX	Extron Middle East +971.4.299.1800 +971.4.299.1880 FAX	Extron Korea +82.2.3444.1571 +82.2.3444.1575 FAX	Extron India 1800.3070.3777 (Inside India Only) +91.80.3055.3777 +91.80.3055.3737 FAX
---	---	--	---	---	---	---	--